

## New ESP control technology

University of Belgrade, Faculty of Electrical Engineering

ESP controller ETF-2005 offers an improved collection of fine particles, improves the energy efficiency of the ESP, benefits on coordinated control of the ESP voltage, rapping and distributed heating, includes the spectrum based flashover suppression and the back corona elimination, and comprises the adaptation mechanism with respect to the fuel parameters.

Although there has been an increasing awareness of the atmospheric pollution, the tendency to limit uncontrolled emissions from all sources has become larger. Enacted legislation is continuously reviewed and is becoming more stringent.

The new control technology for electrostatic precipitators, developed at the ETF Laboratories, University of Belgrade, minimizes the atmospheric pollution problem and offers a number of side benefits. The ETF-2005 package includes the hardware and software bases for this new ESP control technology process.

### ::: New precipitation technology

The new system is based on Digital Voltage Controller ETF-2005 with twin DSP core technology. This device has fully autonomy and flexibility, but his main feature are built in adaptive algorithm of control the electrostatic precipitators. All in purpose of achieving the maximum collection efficiency for both large and small electrostatic precipitators.



Fig. 1. ETF-2005, twin DSP core digital voltage controller

### ::: Adaptive intermittent control

Digital Voltage Controller ETF-2005, comprises a number of operating modes. With adaptive intermittent control, significant increase in the collection and energy efficiency is offered. When handling high resistivity dust produced by combustion of low sulphur coal, this algorithm meets the highest emission standards.

Intermittent control represents precipitation with modulated power, where the thyristor firing is held off for specific period of time, based on feedback from opacity meter, and hence suppress a certain number of half cycles of the primary current within each intermittence period. As a result, savings in electrical power and improvement in the collection efficiency of precipitations are achieved. This algorithm cuts down the back corona phenomenon, and re-entry of collected particles.

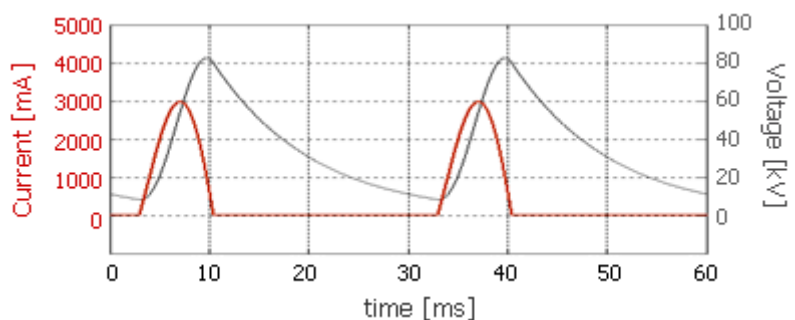

Fig 2. Voltage and current of intermittent control

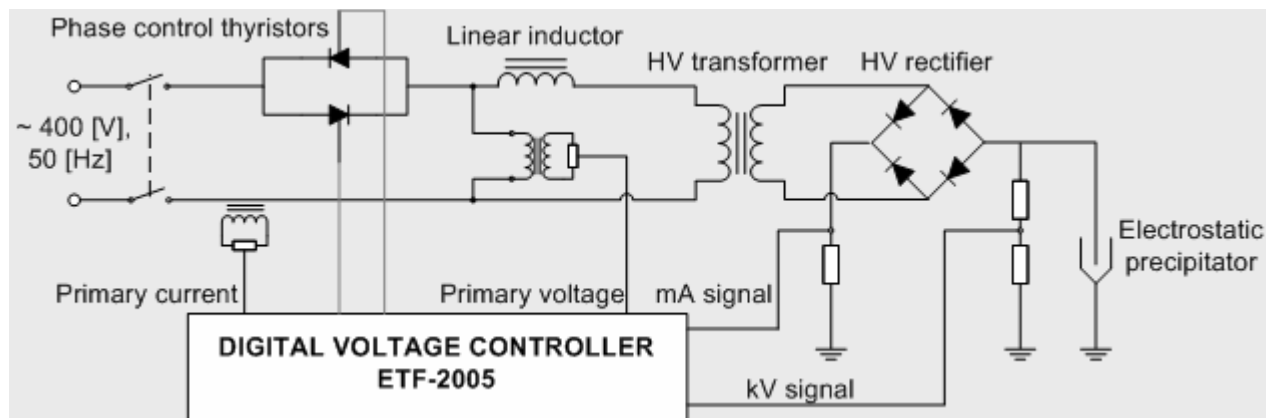

Fig 3. Digital control of a high voltage power supply

Digital Voltage Controller receives the information about actual emission of concentrated dust, and due to adaptive algorithm of intermittent control, maintains the emission under requiring  $50 \text{ mg/Nm}^3$ , keeping at the same time the power consumption at the minimum. The result is a significant energy saving.

### ::: Integrated rapping, heating and PLC functionality

The twin-DSP ETF-2005 integrates the Digital Voltage Controller along with the Programmable Logical Controller (PLC), capable of handling the auxiliary equipment of the electrostatic precipitator, such as the heaters for support and rotating insulators, heaters for hoppers and motor-driven mechanical rapping system and other minor processes. PLC is implemented within the digital signal processor. Local communication between voltage controller DSP and logical controller DSP is CAN 2.0B. This multiprocessor twin DSP core approach increases reliability and offers high flexibility.

Integrated logical controller provides MODBUS RTU communication channel which links the ESP group of sections with the central computer, effectuating SCADA functions for the whole block.

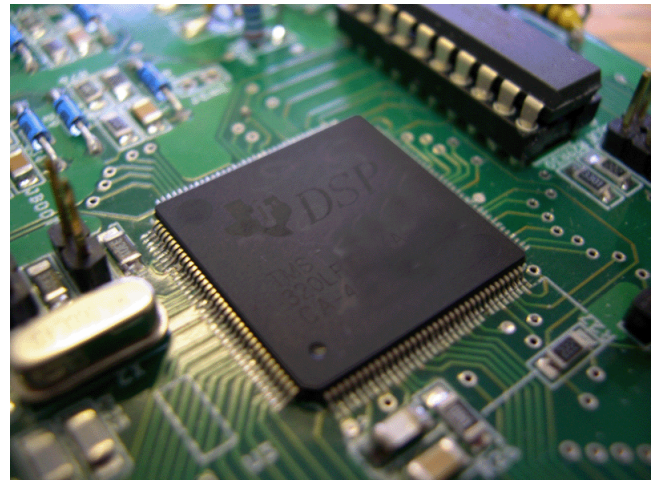

Fig 4. Digital Signal Processor

### ::: Coordination between rapping and voltage controller

With the PLC and voltage control fully integrated, coordination of rapping sequences and applied DC voltage pulses are implemented. A practical advantage of this is much better rapping and cleaning of collecting electrodes, due to a simultaneous modulation of the applied voltage. During the rapping of electrodes, Digital Voltage Controller reduces applied voltage to the specific filter section. Electrical forces which hold the layers of ash, are reduced to enable an efficient cleaning of collecting electrodes.

## ::: Parameter estimation of DC-current spectrum

Very fast DSP cores provide real time parameter estimation of the DC-current spectrum, which allows back corona detection, the estimation of the dust layer thickness, early corona detection and prevention of arcing. Hence, de-ionization intervals are rarely used, and the precipitation efficiency increases. DC-current contains, namely, the corona parameters. This eliminates the need for the operator to adjust the references manually in cases when the coal/fuel parameters change.

## ::: Advantages of new ESP control technology:

- Improved collection of fine particles
- Improved energy efficiency
- Coordinated control of the ESP voltage, rapping and distributed heating
- Spectrum based flashover suppression and the back corona elimination
- Adaptation mechanism with respect to the fuel parameters
- Size, weight and financial savings
- Flexibility and modularity

Contact:  
Prof. Slobodan N. Vukosavić  
E-mail: [boban@ieee.org](mailto:boban@ieee.org)  
vukosavic.etf.bg.ac.yu



UNIVERSITY OF BELGRADE  
FACULTY OF ELECTRICAL ENGINEERING

Bulevar kralja Aleksandra 73 • 11000 Belgrade • Serbia and Montenegro • P.O. Box 816  
• Account:40803-603-1-4335